

1W, AC/DC converter

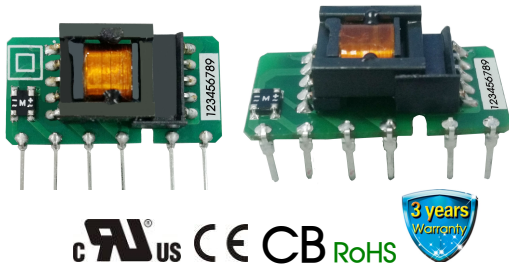

FEATURES

- Ultra wide input voltage range: 85 - 305VAC/70 - 430VDC
- AC and DC dual-use (input from the same terminal)
- Compact size, High power density
- Output short circuit, over-current protection
- IEC60950, UL60950, EN60950 approval

SLS01-15BxxSS (-F) series is a high efficiency green power modules provided by schmid-m. The features of this series are: Accept either AC or DC input, wide input voltage, high efficiency, low power consumption, safety isolation etc. All models are particularly suitable for the applications such as industrial, electric power, instrumentation, smart home which do not have high requirement on EMC. EMC application circuit must be added if the products need to be applied to EMC harsh environment .

Selection Guide

Certification	Part No.	Output Power	Nominal Output Voltage and Current(Vo/Io)	Efficiency (230VAC, %/Typ.)	Max. Capacitive Load (uF)
UL/CE/CB	SLS01-15B05SS(-F)*	1W	5V/200mA	66	220
	SLS01-15B09SS(-F)		9V/111mA	67	100
	SLS01-15B12SS(-F)		12V/83mA	70	100
	SLS01-15B15SS(-F)		15V/67mA	69	100
	SLS01-15B24SS(-F)		24V/42mA	68	100

Note: *The model of 90 degrees of corner is with -F. For example the SLS01-15B12SS of 90 degrees of corner product is SLS01-15B12SS-F.

Input Specifications

Item	Operating Conditions	Min.	Typ.	Max.	Unit
Input Voltage Range	AC input	85	--	305	VAC
	DC input	70	--	430	VDC
Input frequency		47	--	63	Hz
Input current	115VAC	--	--	0.12	A
	277VAC	--	--	0.06	
Inrush current	115VAC	--	9	--	
	277VAC	--	15	--	
Recommended External Input Fuse		1A, slow fusing, necessary			
Hot Plug		Unavailable			

Output Specifications

Item	Operating Conditions	Min.	Typ.	Max.	Unit
Output Voltage Accuracy	SLS01-15B05SS(-F)	--	--	±8	%
	SLS01-15B09SS(-F)	--	--	±5	
	SLS01-15B12SS(-F)	--	--		
	SLS01-15B15SS(-F)	--	--		
	SLS01-15B24SS(-F)	--	--		
Line Regulation	Full load	--	±1.5	--	
Load Regulation	5% - 100% load	5V/9V/12V/15V	--	±3.0	--
		24V	--	±6.0	--
Ripple & Noise*	20MHz bandwidth (peak-peak value)	--	50	120	mV
Temperature Coefficient		--	±0.15	--	%/°C
Stand-by Power Consumption	5V/9V/12V/15V	--	0.15	0.25	W
	24V	--	0.2	0.3	
Short Circuit Protection		Continuous, self-recovery			

AC/DC Converter

SLS01-15BxxSS(-F) Series

Over-current Protection		110 - 500%Io, self-recovery			
Min. Load		5	--	--	%
Hold-up Time	230VAC input	150	180	--	ms

Note: *Ripple and noise are measured by "parallel cable" method, please see AC-DC Converter Application Notes for specific operation.

General Specifications

Item	Operating Conditions	Min.	Typ.	Max.	Unit
Isolation Voltage	Input-output	3000	--	--	VAC
Operating Temperature		-40	--	+85	°C
Storage Temperature		-40	--	+105	
Storage Humidity		--	--	85	%RH
Switching Frequency		--	--	100	kHz
Safety Standard		IEC60950/EN60950/UL60950			
Safety Certification		IEC60950/EN60950/UL60950			
Safety Class		CLASS II			
MTBF	MIL-HDBK-217F@25°C	>200,000 h			

Physical Specifications

Package Dimensions	35.00*18.00*11.00 mm
Weight	6 g (Typ.)
Cooling method	Free air convection

EMC Specifications

EMI	CE	CISPR32/EN55032	CLASS A (See Fig. 1 for typical application circuit)	
		CISPR32/EN55032	CLASS B (See Fig. 2 for recommended circuit)	
	RE	CISPR32/EN55032	CLASS A (See Fig. 1 for typical application circuit)	
		CISPR32/EN55032	CLASS B (See Fig. 2 for recommended circuit)	
EMS	ESD	IEC/EN61000-4-2	Contact ±4KV	Perf. Criteria B
	RS	IEC/EN61000-4-3	10V/m (See Fig. 2 for recommended circuit)	perf. Criteria A
	EFT	IEC/EN61000-4-4	±2KV (See Fig. 1 for typical application circuit)	perf. Criteria B
		IEC/EN61000-4-4	±4KV (See Fig. 2 for recommended circuit)	perf. Criteria B
	Surge	IEC/EN61000-4-5	line to line ±1KV (See Fig. 1 for typical application circuit)	perf. Criteria B
		IEC/EN61000-4-5	line to line±1KV/line to ground ±2KV (See Fig. 2 for recommended circuit)	perf. Criteria B
	CS	IEC/EN61000-4-6	10Vr.m.s (See Fig. 2 for recommended circuit)	perf. Criteria A
Voltage dips, short interruptions and voltage variations immunity		IEC/EN61000-4-11	0%, 70% (See Fig. 2 for recommended circuit)	perf. Criteria B

Product Characteristic Curve

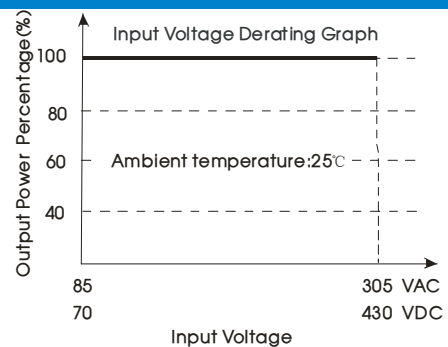
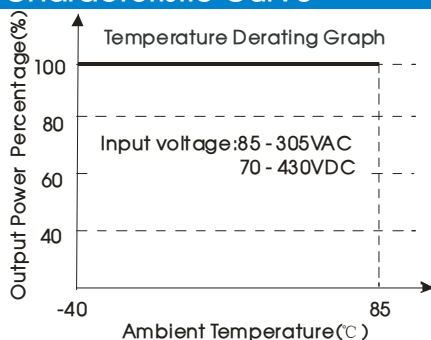

Note: This product is suitable for use in natural air cooling environments, if in a closed environment, please contact our company's FAE.

AC/DC Converter

SLS01-15BxxSS(-F) Series

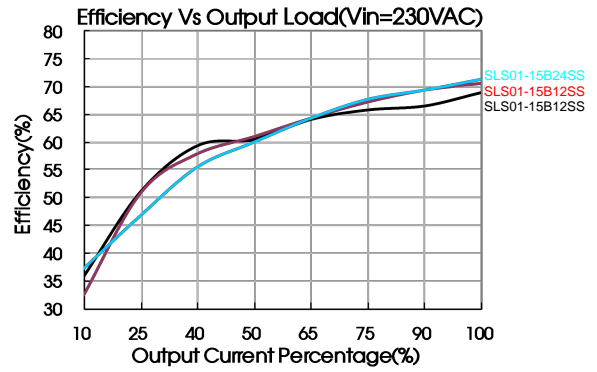
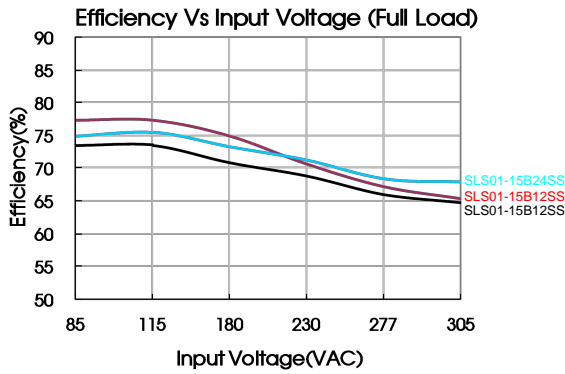

Design Reference

1. Typical application circuit

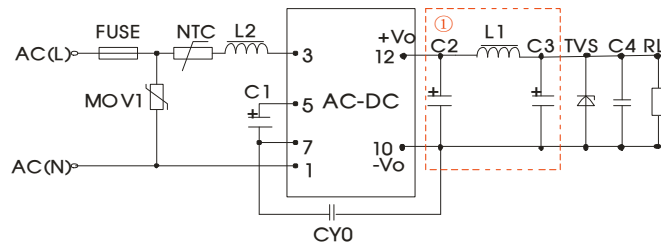

Fig. 1

Note: ① is PI filter circuit.

Model	FUSE (necessary)	C1 (necessary)	L2	NTC	C2 (necessary)	L1 (necessary)	C3 (necessary)	C4	CY0	TVS
SLS01-15B05SS(-F)	1A/ 300V	4.7μF/450V	1mH	15D-5	100μF/ 16V (Solid Capacitor)	2.2μH	68μF/35V	0.1μF/ 50V	1nF/400 VAC	SMBJ7.0A
SLS01-15B09SS(-F)					150μF/ 35V					SMBJ12A
SLS01-15B12SS(-F)					100μF/ 35V					SMBJ20A
SLS01-15B15SS(-F)					100μF/ 35V					SMBJ20A
SLS01-15B24SS(-F)					100μF/ 35V					SMBJ30A

Note:
 C1: AC input, C1 is input filter capacitor (which is required);
 DC input, is a filtering capacitor in EMC Filter (which is required);
 C2 and C3 are output filter capacitors (which is required), C2, C3 and L1 form a pi-type filter circuit, they are recommended to be high frequency and low impedance electrolytic capacitors. Capacitance and rated ripple current of capacitors refer to the datasheets provided by the manufactures. Capacitor voltage reduced to at least 80%. C4 is a ceramic capacitor, which is used to filter high frequency noise. Current of L1 and L2 refer to the datasheets provided by the manufactures, current derating to at least 80%. TVS is a recommended component to protect post-circuits (if converter fails). External input MOV1 model is recommended to use S14K350.

2. EMC solution-recommended circuit

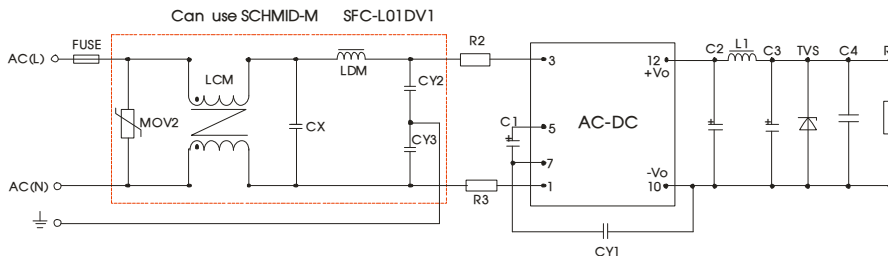



Fig 2

AC/DC Converter

SLS01-15BxxSS(-F) Series

Components	Recommend Parameter
MOV2	S14K350
CY1/CY2/CY3	1nF/400VAC
CX	0.1 μ F/275VAC
LCM	3.5mH
LDM	0.33mH
R2/R3	33 Ω /3W
FUSE (necessary)	1A/300V, slow fusing
Can use SCHMID-M 's SFC-L01DV1 EMC model	

SLS01-15BxxSS Dimensions and Recommended Layout

THIRD ANGLE PROJECTION 

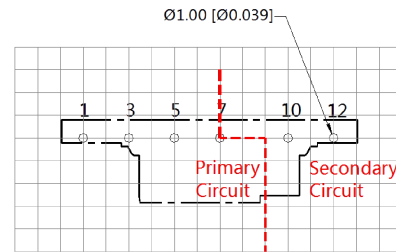
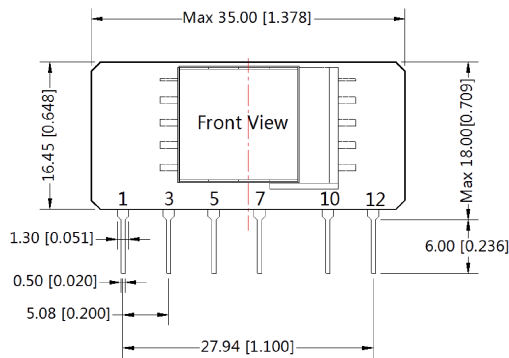

Note: Grid 2.54*2.54mm

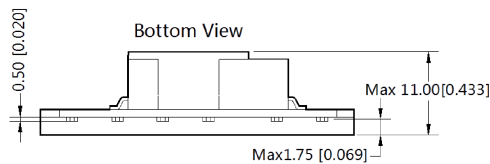

Note:
 Unit: mm[inch]
 Pin section tolerances: $\pm 0.10[\pm 0.004]$
 General tolerances: $\pm 0.50[\pm 0.020]$
 The layout of the device is for reference only, please refer to the actual product

Pin-Out	
Pin	Function
1	AC (N)
3	AC (L)
5	+V(cap)
7	-V(cap)
10	-Vo
12	+Vo

- 1.It is necessary to add C1 between pin5 and pin7 ;
- 2.It is necessary to add pi-type filter circuit to the output,such as the typical application of Figure 1;
- 3.It is needed to have distance $\geq 6.$ between external componets in pri secondary circuit.

AC/DC Converter

SLS01-15BxxSS(-F) Series

SLS01-15BxxSS -F Dimensions and Recommended Layout

THIRD ANGLE PROJECTION 

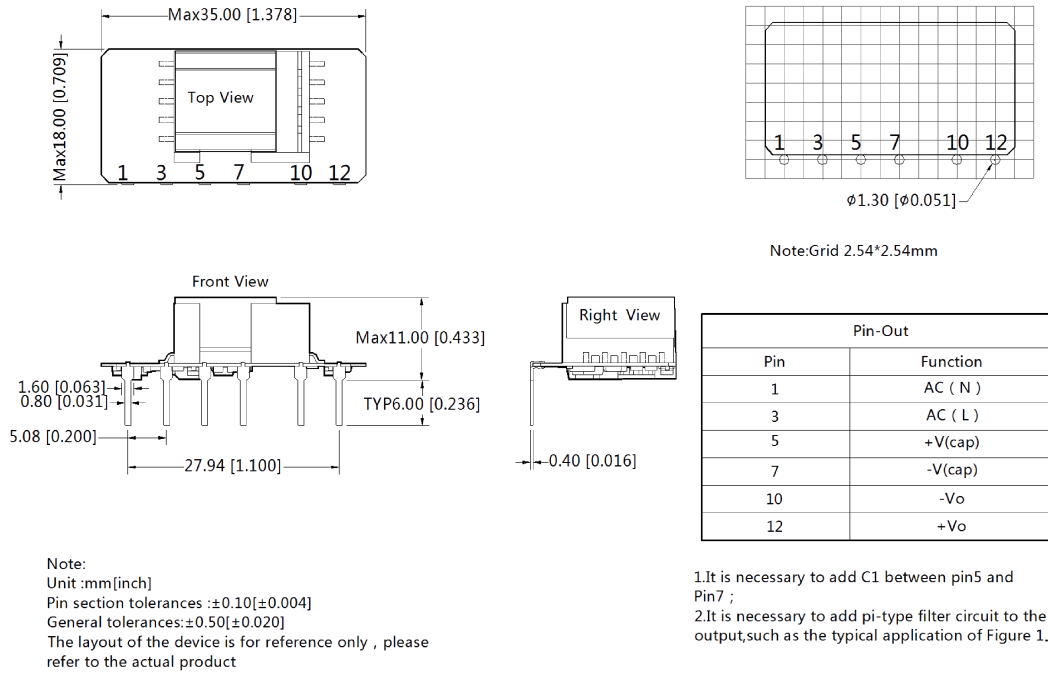

Note:

- External electrolytic capacitors are required to modules, more details refer to typical applications;
- This part is open frame, at least 6.4mm safety distance between the primary and secondary external components of the module is needed to meet the safety requirement;
- Unless otherwise specified, parameters in this datasheet were measured under the conditions of $T_a=25^{\circ}\text{C}$, humidity<75%, nominal input voltage (115V and 230V) and rated output load;
- In order to increase the conversion efficiency of the product with light load in the design, the product will have audio noise when it is operating, but don't affect the product's reliability and performance;
- Module required dispensing fixed after assembled;
- All index testing methods in this datasheet are based on our Company's corporate standards;
- We can provide product customization service, please contact our technicians directly for specific information;
- Products are related to laws and regulations: see "Features" and "EMC";
- Our products shall be classified according to ISO14001 and related environmental laws and regulations, and shall be handled by qualified units.