



SB-1W Series

1W 2:1 Regulated Single & Dual output

Features

- 8 Pin SIL / 16 Pin DIL
- Wide 2:1 Input Range
- Full SMD Technology
- 1000 VDC Isolation, Up to 3000 VDC
- Continuous Short Circuit Protection
- Efficiency up to 77%
- -40 ~ 85°C Operation Temperature Range
- Plastic Case Standard, Optional Metal Case
- Remote on/off Control Optional



The SB series is a family of cost effective 1W single & dual output DC-DC converters. These converters combine non-conductive black plastic case in a 8-pin SIL / 16-pin DIL package with high performance features such as 1000 VDC~3000Vdc input/output isolation voltage, continuous short circuit protection with automatic restart and tight line / load regulation. Devices are encapsulated using flame retardant resin. Input voltages of 5,12,24 and 48 with output voltage of 3.3, 5, 9, 12, 15, 24, ± 3.3 , ± 5 , ± 9 , ± 12 , ± 15 , ± 24 Vdc. High performance features include high efficiency operation up to 77% and output voltage accuracy of $\pm 2\%$ maximum.

All specifications typical at $T_a=25^\circ\text{C}$, nominal input voltage and full load unless otherwise specified

OUTPUT SPECIFICATIONS		GENERAL SPECIFICATIONS	
Voltage Accuracy	$\pm 2\%$	Efficiency	See table
Line Regulation	$\pm 0.5\%$	I/O Isolation Voltage	
Load Regulation (From 25% ~100% Loading)	$\pm 1\%$	I/O 1 min(flash tested for 3sec)	1000~3000Vdc
Cross Regulation (Dual Output) (4)	$\pm 5\%$	Metal Case/Input&Output	1000Vdc
Ripple & Noise (20 Mhz bandwidth)(5)	80mV pk-pk	I/O Isolation Capacitance	60 pF
Short Circuit Protection	Indefinite(Automatic Recovery)	I/O Isolation Resistance	1000M Ohm, min
Temperature Coefficient	$\pm 0.02\%/^\circ\text{C}$	Switching Frequency	100~650kHz
Capacitive Load(6)	See table	Humidity	95% rel H
		Reliability Calculated MTBF(MIL-HDBK-217 F)	>2.732 Mhrs
		Safety Standard : (designed to meet)	IEC 60950-1:2001
		Remote On/Off(CTRL) (see note 11.)	
INPUT SPECIFICATIONS		ENVIRONMENT SPECIFICATIONS	
Voltage Range	See table	Operating Temperature	$-40^\circ\text{C} \sim 85^\circ\text{C}$ (See Derating Curve)
Max. Input Current	See table	Maximum Case Temperature	100°C
No-Load Input Current	See table	Storage Temperature	$-40^\circ\text{C} \sim 125^\circ\text{C}$
Input Filter	Capacitor	Cooling	Nature Convection
Input Reflected Ripple Current(7)	35mA pk-pk		
PHYSICAL SPECIFICATIONS		ABSOLUTE MAXIMUM RATINGS(8)	
Case Material	Non-conductive Black Plastic(UL94V-0 rated)	These are stress ratings. Exposure of devices to any of these conditions may adversely affect long-term reliability.	
	Nickel-coated Copper	Input Voltage(100mS)	
Pin Material		05 Modes	-0.7~12 Vdc
SIP Case	Alloy42 Solder-coated	12 Modes	-0.7~24 Vdc
DIP Case	$\varnothing 0.5\text{mm}$ Brass Solder-coated	24 Modes	-0.7~40 Vdc
Potting Material	Epoxy (UL94V-0 rated)	48 Modes	-0.7~80 Vdc
Weight	4.5g(SIP)~6g(DIP)	Soldering Temperature	260°C
	Metal Case/6.5g(SIP)~8g(DIP)	1.5mm from case 10sec.	
Dimensions			
SIP Case	0.86"x0.36"x0.44"		
DIP Case	0.92"x0.55"x0.40"		

SB - 1W 2:1 Regulated Single & Dual output

PARTNUMBER STRUCTURE

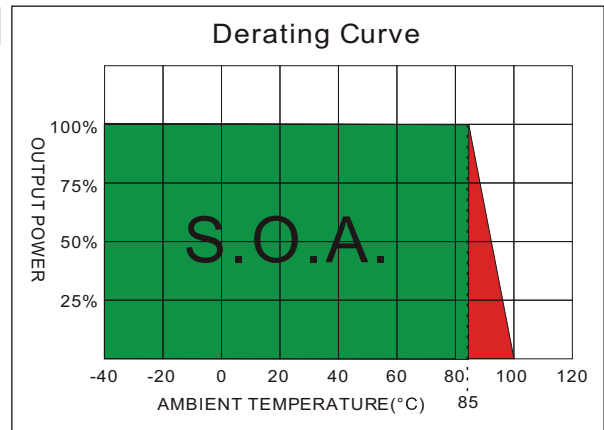
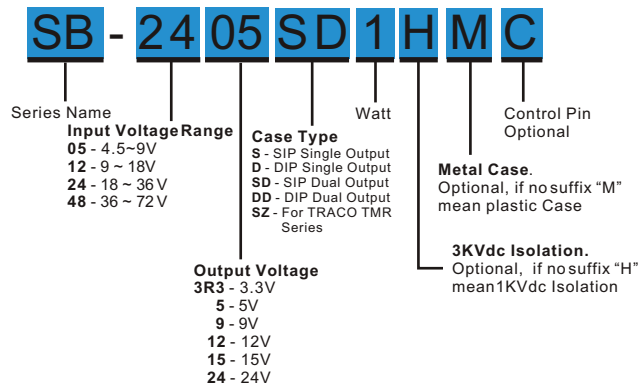

MODEL SELECTION GUIDE

MODEL NUMBER	INPUT			OUTPUT			EFFICIENCY @FL(%)	Capacitor Load(uF)
	Voltage Range(Vdc)	No-Load Current(mA)	Full Load Current(mA)	Voltage (Vdc)	Min.load (mA)	Full.load (mA)		
SB-053R3S1	4.5-9	15	298	3.3	76	303	67	3300
SB-0505S1	4.5-9	15	298	5.0	50	200	67	3300
SB-0509S1	4.5-9	40	285	9.0	28	111	70	470
SB-0512S1	4.5-9	55	285	12.0	21	83	70	470
SB-0515S1	4.5-9	55	285	15.0	17	67	70	470
SB-0524S1	4.5-9	70	294	24.0	10	42	68	220
SB-123R3S1	9-18	15	119	3.3	76	303	70	3300
SB-1205S1	9-18	15	115	5.0	50	200	72	3300
SB-1209S1	9-18	15	108	9.0	28	111	77	470
SB-1212S1	9-18	15	108	12.0	21	83	77	470
SB-1215S1	9-18	15	108	15.0	17	67	77	470
SB-1224S1	9-18	15	114	24.0	10	42	73	220
SB-243R3S1	18-36	8	59	3.3	76	303	70	3300
SB-2405S1	18-36	8	57	5.0	50	200	72	3300
SB-2409S1	18-36	8	55	9.0	28	111	75	470
SB-2412S1	18-36	8	55	12.0	21	83	75	470
SB-2415S1	18-36	8	55	15.0	17	67	75	470
SB-2424S1	18-36	8	55	24.0	10	42	75	220
SB-483R3S1	36-72	6	31	3.3	76	303	66	3300
SB-4805S1	36-72	6	30	5.0	50	200	68	3300
SB-4809S1	36-72	6	29	9.0	28	111	70	470
SB-4812S1	36-72	6	29	12.0	21	83	70	470
SB-4815S1	36-72	6	29	15.0	17	67	70	470
SB-4824S1	36-72	6	30	24.0	10	42	68	220
SB-053R3D1	4.5-9	15	298	3.3	76	303	67	3300
SB-0505D1	4.5-9	15	298	5.0	50	200	67	3300
SB-0509D1	4.5-9	40	285	9.0	28	111	70	470
SB-0512D1	4.5-9	55	285	12.0	21	83	70	470
SB-0515D1	4.5-9	55	285	15.0	17	67	70	470
SB-0524D1	4.5-9	70	294	24.0	10	42	68	220
SB-123R3D1	9-18	15	119	3.3	76	303	70	3300
SB-1205D1	9-18	15	115	5.0	50	200	72	3300
SB-1209D1	9-18	15	108	9.0	28	111	77	470
SB-1212D1	9-18	15	108	12.0	21	83	77	470
SB-1215D1	9-18	15	108	15.0	17	67	77	470
SB-1224D1	9-18	15	114	24.0	10	42	73	220

Suffix "H" means 3KVdc isolation

Suffix "C" means with control pin

Suffix "M" means with Metal Case

SB - 1W 2:1 Regulated Single & Dual output

MODEL SELECTION GUIDE

MODEL NUMBER	INPUT			OUTPUT			EFFICIENCY @FL(%)	Capacitor Load(µF)
	Voltage Range(Vdc)	No-Load Current(mA)	Full Load Current(mA)	Voltage (Vdc)	Min.load (mA)	Full.load (mA)		
SB-243R3D1	18-36	8	59	3.3	76	303	70	3300
SB-2405D1	18-36	8	57	5.0	50	200	72	3300
SB-2409D1	18-36	8	55	9.0	28	111	75	470
SB-2412D1	18-36	8	55	12.0	21	83	75	470
SB-2415D1	18-36	8	55	15.0	17	67	75	470
SB-2424D1	18-36	8	55	24.0	10	42	75	220
SB-483R3D1	36-72	6	31	3.3	76	303	66	3300
SB-4805D1	36-72	6	30	5.0	50	200	68	3300
SB-4809D1	36-72	6	29	9.0	28	111	70	470
SB-4812D1	36-72	6	29	12.0	21	83	70	470
SB-4815D1	36-72	6	29	15.0	17	67	70	470
SB-4824D1	36-72	6	30	24.0	10	42	68	220
SB-053R3SD1	4.5-9	15	285	±3.3	±38	±152	70	±1000
SB-0505SD1	4.5-9	15	270	±5.0	±25	±100	74	±1000
SB-0509SD1	4.5-9	20	270	±9.0	±14	±56	74	±220
SB-0512SD1	4.5-9	20	266	±12.0	±10	±42	75	±220
SB-0515SD1	4.5-9	40	285	±15.0	±8	±33	70	±220
SB-0524SD1	4.5-9	70	298	±24.0	±5	±21	67	±100
SB-123R3SD1	9-18	15	119	±3.3	±38	±152	70	±1000
SB-1205SD1	9-18	15	115	±5.0	±25	±100	72	±1000
SB-1209SD1	9-18	15	109	±9.0	±14	±56	76	±220
SB-1212SD1	9-18	15	109	±12.0	±10	±42	76	±220
SB-1215SD1	9-18	15	112	±15.0	±8	±33	74	±220
SB-1224SD1	9-18	40	124	±24.0	±5	±21	67	±100
SB-243R3SD1	18-36	8	59	±3.3	±38	±152	70	±1000
SB-2405SD1	18-36	8	59	±5.0	±25	±100	70	±1000
SB-2409SD1	18-36	8	54	±9.0	±14	±56	76	±220
SB-2412SD1	18-36	8	54	±12.0	±10	±42	77	±220
SB-2415SD1	18-36	8	55	±15.0	±8	±33	75	±220
SB-2424SD1	18-36	20	59	±24.0	±5	±21	70	±100
SB-483R3SD1	36-72	6	30	±3.3	±38	±152	70	±1000
SB-4805SD1	36-72	6	30	±5.0	±25	±100	70	±1000
SB-4809SD1	36-72	6	28	±9.0	±14	±56	74	±220
SB-4812SD1	36-72	6	27	±12.0	±10	±42	76	±220
SB-4815SD1	36-72	6	29	±15.0	±8	±33	72	±220
SB-4824SD1	36-72	12	30	±24.0	±5	±21	70	±100
SB-053R3DD1	4.5-9	15	285	±3.3	±38	±152	70	±1000
SB-0505DD1	4.5-9	15	270	±5.0	±25	±100	74	±1000
SB-0509DD1	4.5-9	20	270	±9.0	±14	±56	74	±220
SB-0512DD1	4.5-9	20	266	±12.0	±10	±42	75	±220
SB-0515DD1	4.5-9	40	285	±15.0	±8	±33	70	±220
SB-0524DD1	4.5-9	70	298	±24.0	±5	±21	67	±100
SB-123R3DD1	9-18	15	119	±3.3	±38	±152	70	±1000
SB-1205DD1	9-18	15	115	±5.0	±25	±100	72	±1000
SB-1209DD1	9-18	15	109	±9.0	±14	±56	76	±220
SB-1212DD1	9-18	15	109	±12.0	±10	±42	76	±220
SB-1215DD1	9-18	15	112	±15.0	±8	±33	74	±220
SB-1224DD1	9-18	40	124	±24.0	±5	±21	67	±100
SB-243R3DD1	18-36	8	59	±3.3	±38	±152	70	±1000
SB-2405DD1	18-36	8	59	±5.0	±25	±100	70	±1000
SB-2409DD1	18-36	8	54	±9.0	±14	±56	76	±220
SB-2412DD1	18-36	8	54	±12.0	±10	±42	77	±220
SB-2415DD2	18-36	8	55	±15.0	±8	±33	75	±220
SB-2424DD2	18-36	20	59	±24.0	±5	±21	70	±100

Suffix "H" means 3KVdc isolation

Suffix "C" means with controlpin

Suffix "M" means with Metal Case

MODEL SELECTION GUIDE

MODEL NUMBER	INPUT			OUTPUT			EFFICIENCY @FL(%)	Capacitor Load(μF)
	Voltage Range(Vdc)	No-Load Current(mA)	Full Load Current(mA)	Voltage (Vdc)	Min.load (mA)	Full.load (mA)		
SB-483R3DD1	36-72	6	30	±3.3	±38	±152	70	±1000
SB-4805DD1	36-72	6	30	±5.0	±25	±100	70	±1000
SB-4809DD1	36-72	6	28	±9.0	±14	±56	74	±220
SB-4812DD1	36-72	6	27	±12.0	±10	±42	76	±220
SB-4815DD1	36-72	6	29	±15.0	±8	±33	72	±220
SB-4824DD1	36-72	12	30	±24.0	±5	±21	70	±100

Suffix "H" means 3KVdc isolation

Suffix "C" means with control pin

Suffix "M" means with Metal Case

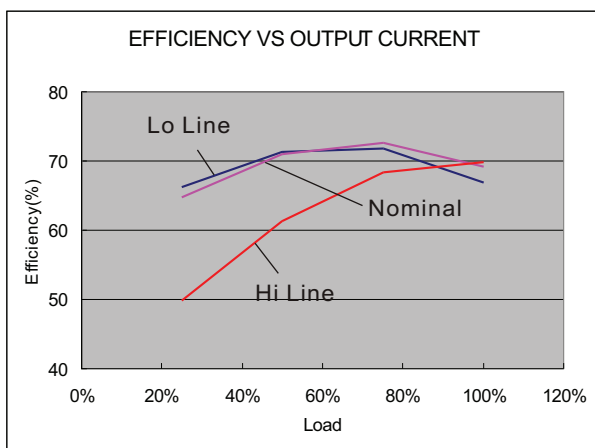

05 Models

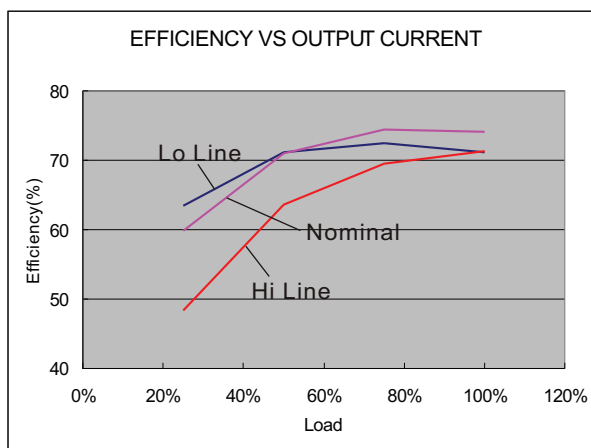

12 Models

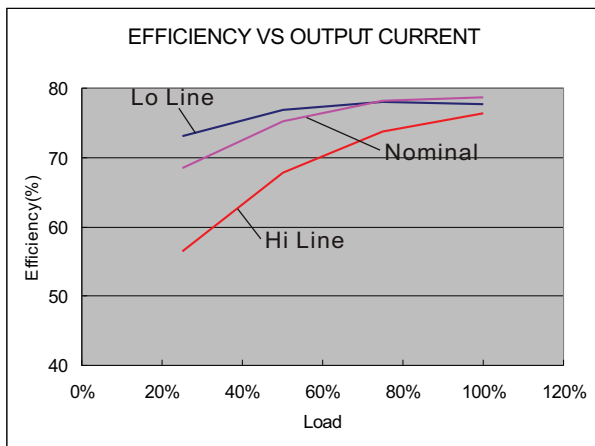

24 Models

NOTE

1. Maximum value at nominal input voltage and full load.
2. Typical value at nominal input voltage and full load.
3. 25% minimum loading is needed.
4. One load is 25% to 100% load, the other load is 100% load, the output voltage variable rate is within ±5%.
5. Ripple/Noise measured with 20MHz bandwidth.
6. Test by nominal input voltage and constant resistor load.
7. Measured Input reflected ripple current with a simulated source inductance of 12μH.
8. Exceeding the absolute ratings of the unit could cause damage.
It is not allowed for continuous operating.
9. Operation under no-load conditions will not damage these devices, however they may not meet all listed specifications.
10. It's necessary to add minimum capacitor in output for some models, please check single model datasheet for detail value.

SB - 1W 2:1 Regulated Single & Dual output

NOTE

11. MCU (Master Control Unit)

The MCU Pin Voltage is referenced to -Vin(Pin 1)

ON:0 ~ 0.8VDC Max.

(Short circuit Pin 1 and Pin 3) or open circuit

OFF:4.5 to 15VDC Max.

OFF idle current:3.5mA to 15mA Max.

Connection example



MECHANICAL SPECIFICATIONS

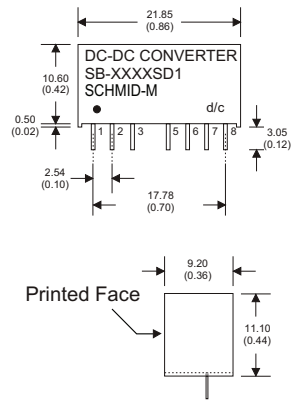

PIN CONNECTIONS				PIN CONNECTIONS			
PIN NUMBER	SINGLE	DUAL/(SD)	DUAL/(SZ)	PIN NUMBER	SINGLE+C	DUAL/(SD+C)	DUAL/(SZ+C)
1	-V Input	-V Input	-V Input	1	-V Input	-V Input	-V Input
2	+V Input	+V Input	+V Input	2	+V Input	+V Input	+V Input
3	N.P.	N.C.	N.C.	3	Remote On/Off	Remote On/Off	Remote On/Off
5	N.P.	N.C.	N.C.	5	N.C.	N.C.	N.C.
6	+V Output	+V Output	+V Output	6	+V Output	+V Output	+V Output
7	-V Output	-V Output	Common	7	-V Output	-V Output	Common
8	N.C.	Common	-V Output	8	N.C.	Common	-V Output

(The Pin Connection of high isolation one is the same with normal one.)

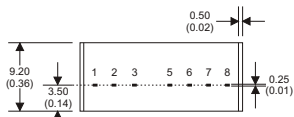

8 Pin SIL Package

Non-Conductive Plastic

Notes: All dimensions are typical in millimeters (inches).

1. Pin diameter: 0.5 ± 0.05 (0.02 ± 0.002)
2. Pin pitch tolerance: ± 0.35 (± 0.014)
3. Case Tolerance: ± 0.5 (± 0.02)

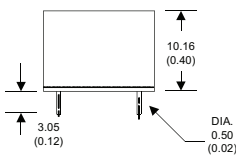
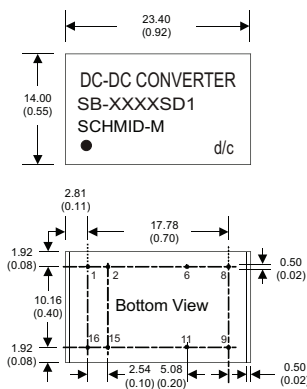

16 Pin DIL Package

Non-Conductive Plastic

Notes: All dimensions are typical in millimeters (inches).

1. Pin diameter: 0.5 ± 0.05 (0.02 ± 0.002)
2. Pin pitch tolerance: ± 0.35 (± 0.014)
3. Case Tolerance: ± 0.5 (± 0.02)

PIN CONNECTIONS		
PIN NUMBER	SINGLE	DUAL
1	-V Input	-V Input
2	-V Input	-V Input
6	N.C.	Common
8	N.C.	-V Output
9	+V Output	+V Output
11	-V Output	Common
15	+V Input	+V Input
16	+V Input	+V Input

(The Pin Connection of high isolation one is the same with normal one.)

SB - 1W 2:1 Regulated Single & Dual output

MECHANICAL SPECIFICATIONS

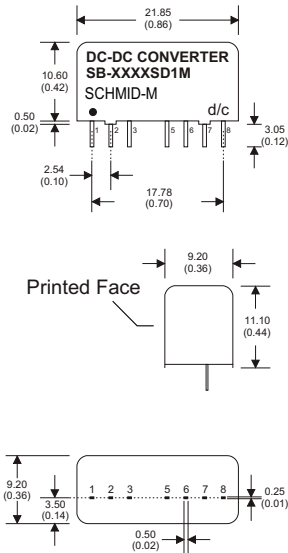

PIN CONNECTIONS			
PIN NUMBER	SINGLE	DUAL/(SD)	DUAL/(SZ)
1	-V Input	-V Input	-V Input
2	+V Input	+V Input	+V Input
3	N.P.	N.C.	N.C.
5	N.P.	N.C.	N.C.
6	+V Output	+V Output	+V Output
7	-V Output	-V Output	Common
8	N.C.	Common	-V Output

PIN CONNECTIONS			
PIN NUMBER	SINGLE+C	DUAL/(SD+C)	DUAL/(SZ+C)
1	-V Input	-V Input	-V Input
2	+V Input	+V Input	+V Input
3	Remote On/Off	Remote On/Off	Remote On/Off
5	N.C.	N.C.	N.C.
6	+V Output	+V Output	+V Output
7	-V Output	-V Output	Common
8	N.C.	Common	-V Output

(The Pin Connection of high isolation one is the same with normal one.)

**8 Pin SIL Package
Nickel-Coated Copper**

- Notes: All dimensions are typical in millimeters (inches).
1. Pin diameter: 0.5 ± 0.05 (0.02 ± 0.002)
 2. Pin pitch tolerance: ± 0.35 (± 0.014)
 3. Case Tolerance: ± 0.5 (± 0.02)

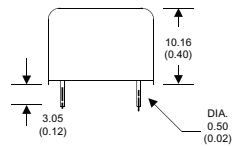
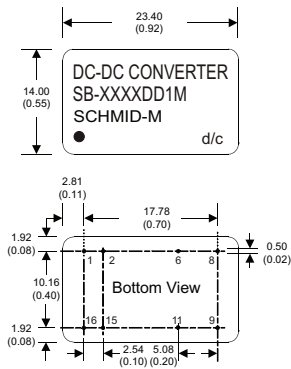

**16 Pin DIL Package
Nickel-Coated Copper**

- Notes: All dimensions are typical in millimeters (inches).
1. Pin diameter: 0.5 ± 0.05 (0.02 ± 0.002)
 2. Pin pitch tolerance: ± 0.35 (± 0.014)
 3. Case Tolerance: ± 0.5 (± 0.02)

PIN CONNECTIONS		
PIN NUMBER	SINGLE	DUAL
1	-V Input	-V Input
2	-V Input	-V Input
6	N.C.	Common
8	N.C.	-V Output
9	+V Output	+V Output
11	-V Output	Common
15	+V Input	+V Input
16	+V Input	+V Input

(The Pin Connection of high isolation one is the same with normal one.)